

Short Operating Instructions for EDIC-mini Ray+ A105 recorders

Purpose:

The Edic-mini Ray+ series of professional voice recorders with an adaptive directional pattern and advanced features including playback mode in the Recorder itself and OLED indicator. The use of 8 digital microphones with built-in 24-bit audio codec provides maximum recording quality in the most difficult conditions, high acoustic sensitivity (up to 20 meters) and a wide dynamic range (24 bit). Availability of markers allows it to confirm the authenticity of the recording in court. Recording is performed onto microSD card up to 256GB, which provides up to 1 year of continuous recording.

When recording in noisy, echoing premises at long distance it is impossible to achieve the desired recording quality using conventional recorders with 1 or 2 microphones. The problem is that when recording at considerable distance the recorder records not only the necessary signal, but also some external noise and the reflection of sound. This interference increases quadratically depending on the distance from the sound source and at the distance of several meters it really can drown out the desired signal. The only solution is to form a signal source direction pattern with maximum drowning of signal from other directions.

To generate a direction pattern there are 8 microphones used in the **Edic-mini Ray+ recorders** forming so-called phased array (similar to the one used in radars).

The application of 8 microphones also reduces the inherent noise of the microphones by 2.5 times. In the end, record gain from the use of 8 microphones can be from 2 up to 6 (depending on the recording conditions) as compared to recorder with one microphone.

Main Technical Characteristics of the Recorders

Model	Power Supply	Dimensions (mm)	Weight (g)	Autonomy (h)*	Signal-to-noise ratio (dB)	Sensitivity (dB)	Sampling rates (kHz)	Frequency band (kHz)	Charging period
A105	rechargeable battery	8x33x100	30	90	79	-80	8;16;32	0,1-15	once a year

*The parameter of autonomy is specified for Record Mode 8KHz/8 bit, in case of higher sampling rate or bitrate, autonomy value is lower. Autonomy value considerably depends on the model of microSD in use and can vary to be higher or lower. Average current consumption: in record mode (8kHz / 8bit) 2.7mA, in standby mode 2.5mA without card installed.

Operating and storage temperature range 0- + 50C

Operating lifetime 3 years

Features:

1. OLED screen
2. 8 record channels (available for 1, 2, 4, 6 and 8 microphones)
3. Stereo recording with MEMS microphones with 24-bit audio codec, dynamic range of the codec 144 dB, signal/noise ratio 79 dB.
4. Acoustic sensitivity up to 20m, recording frequency range 0.1-15kHz, sampling rates of 8, 16, 32kHz
5. Voice activation system (VAS);
6. Timers to enable recording at the preset time (4 pcs.); (single and daily)
7. Linear and circular recording;
8. Digital authenticity markers preventing unauthorized modification of files; Calendar, attachment of records to the time and date;
9. Password encryption of records made;
10. Control and indication: buttons and LEDs;
11. Records playback from the Recorder (through headphones).

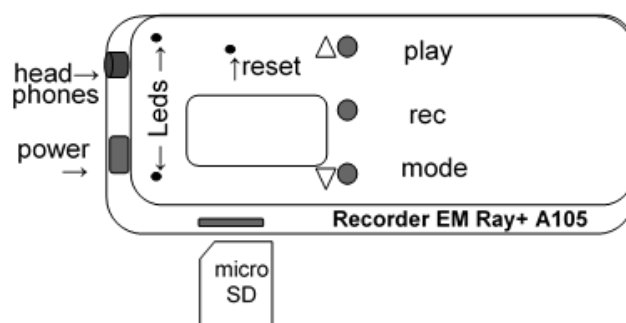

Operating the Recorder

1. Battery Charging

Before starting make sure the rechargeable battery is charged. Charge the battery if necessary.

Connect the supplied cable to the micro USB port of the Recorder, then connect it to the USB port of the PC, or to any other USB charger with an output voltage of 5V and a current of at least 500 mA. During charging, the red LED will be on, upon completion the green LED is on. Full charging takes 3-4 hours.

IMPORTANT: After the Recorder has been charged, remove the cable from the Recorder to avoid any possible mechanical damage.

2. Preparing microSD Card

MicroSD card which is in the delivery set, doesn't require any preliminary preparation. It has a configuration text file CONFIG_CARD24.INI containing Recorder's settings.

If a new memory card needs to be used, first make sure that the file system installed on the card is FAT32 or ExFat. Next, install a new SD into the Recorder. The Recorder will generate a configuration file. With the first use of a new SD card a long initialization is permissible (up to 1 minute).

3. Recording

To start recording press the REC button once for 1 second. The red LED flashes once and recording starts. During recording, the LED flashes in 2 series, the number of flashes showing:

Number of flashes	Battery charge level (1st series)	Free memory capacity (2nd series)
1	80-100%	75-100%
2	20-80%	50-75%
3	2-20%	25-50%
4		1-25%

To stop recording, press the REC button once for 1 second. Red LED will be on to indicate recording has stopped.

DO NOT REMOVE MEMORY CARD DURING OPERATION OR WHILE THE LED IS ON

Failure to do so may damage the recorded file.

Note: Any number of flash series that is different from the above mentioned states for one of the following contingency situations: 3 flashes - rechargeable battery is discharged, constant flashes of red LED indicate microSD card failure (full, can not be read or not available).

4. Record Playback

The Recorder switches from standby mode to playback mode after a single short pressing of the PLAY button for 1 second. The Recorder start playing the last file recorded, indicating battery status with periodic green flashes. The flashing pattern for assessing battery level is similar to the recording process. Recording can be played back through headphones.

When the end of the current recording is reached, or after moving to the end of the recording using navigation functions, playback stops, which is indicated by a rapid blinking of the green indicator. After that, if neither of the buttons id pressed for 10 seconds, the Recorder goes to standby mode.

5. Configuring the Recorder. Editing configuration file through word processor

First make sure the Recorder is not in record or playback mode. Then remove the microSD card from the Recorder. Using microsd-USB or SD-microSD connect the card to the PC, a smartphone, or tablet. Open the CONFIG_CARD24.ini file using word processor, and start editing. To set the recording parameter, as well as to enable / disable settings, select the corresponding value in the line with the parameter after the "=" symbol.

Editing configuration file from the Recorder

Use 'Mode' button to enter configuration mode. Navigation in configuration mode: 'Play' button - forward, 'Mode' button - back, 'Rec' button - OK. After setting the necessary parameters, make sure to click Save and Close.

Configurator program for creating a configuration file

The supplied microSD card contains a folder with the corresponding software. There is Confiq_card24 prog program in this folder. Also, this program is available for download from www.ts-market.com

- Run the Confiq_card24 prog program on your device, select the required settings and click the button 'Download new settings'
- This program generates a new configuration file for your Recorder.
- Delete the old configuration file from the microSD card replacing it with the newly created one.

This program is designed as a java application, it uses any browser available on the device (your PC, tablet, smartphone, etc.). The program operates offline (no internet connection needed).

Note: before removing the memory card, the Recorder should not be in one of the operating modes, all its indicators being off. Failure to comply with this requirement may lead to an incorrect termination of the process operating the memory card and to the loss of all information on it.

Detailed information on the operation, functions and programming of the Recorder is available in the full operating instructions on the company's website www.ts-market.com.

In Box:

1. Recorder;
2. USB card reader for microSD cards;
3. microSD card;
4. Reader for microSD card;
5. Headphones with 3.5 mm jack;
6. Short operating instructions with a warranty card;
7. Package box.

Warranty

The manufacturer undertakes warranty repair liabilities for 1 year from the date of purchase, but no longer than 2 years from the date of manufacture of the product (warranty does not cover batteries), other rules are regulated by the Law "On Protection of Consumers' Rights".

Further there is usually a long list of cases when the user loses warranty. We have a different approach. We make use of every warranty case as an opportunity to find out the causes and make our products better. Therefore, we are always grateful for any comments and proposals regarding our products, as well as the detailed description of the conditions and causes that led to failure. We appreciate time and skills of our customers, and if the problem is not that complicated, we do not mind if you try to solve the problem yourself. If the attempt to repair was fairly neat, you do not lose your warranty. In case of major breakdowns, chemical exposure or mechanical damage to the Recorder, the manufacturer will not be able to continue the warranty service of this device. Our products have no seals.

If you are experiencing problems with the use of our products, we recommend the following:

1. Go to www.ts-market.com and see a list of common problems (FAQ section) and their solutions. Perhaps there is a solution to your problem.
2. If the problem persists, contact technical support at support@ts-market.com with the detailed description of your problem, the conditions it appeared, the exact product name according to the passport, firmware, software, operating system, and other relevant information. Remember, the better you describe the problem, the sooner it is resolved. Calls and mails like "It doesn't work at all!" are least effective. E-mail correspondence is most effective because it preserves history and minimizes misunderstanding. You will receive a response to your request by e-mail within 24 hours (excluding weekends and holidays).